

## RS485 Option Board for SV-iS5/iH Series

Read this manual carefully before using the RS485 OPTION BOARD  
and follow the instructions exactly.

After reading this manual, keep it at handy for future reference.



**LG Industrial Systems**

*Thank you for purchase of LG RS 485 Option Board!*

## SAFETY PRECAUTIONS

- Always follow safety precautions to prevent accidents and potential hazards from occurring.
- Safety precautions are classified into “WARNING” and “CAUTION” in this manual.



### WARNING

Indicates a potentially hazardous situation which, if not avoided, can result in serious injury or death.



### CAUTION

Indicates a potentially hazardous situation which, if not avoided, can result in minor to moderate injury, or serious damage to the product.

- Throughout this manual we use the following two illustrations to make you aware of safety considerations:



Identifies potential hazards.

Read the message and follow the instructions carefully.



Identifies shock hazards.

Particular attention should be directed because dangerous voltage may be present.

- Keep this manual at handy for quick reference.



## CAUTION

- **Do not touch the CMOS components unless the board is grounded.**  
ESD can cause break down of CMOS components.
- **Do not change the communication cable with the inverter power is applied.**  
Otherwise, there is a danger of connecting error and damage to the board.
- **Make sure to precisely insert the connector of inverter and option board**  
Otherwise, there is a danger of connecting error and damage to the board.
- **Check the parameter unit when setting the parameters.**  
Otherwise, there is a danger of connecting error and damage to the board.

# 1. INTRODUCTION

By using a RS 485 OPTION BOARD, SV-iS5/iH inverter can be connected to a RS 485 network.

## 1.1. When you use the RS 485 Option Card ...

Inverter can be controlled and monitored by the sequence program of the PLC or other master module.

Up to 31 drives or other slave devices may be connected in a multi-drop fashion on the RS-485 network and may be monitored or controlled by a single PLC or PC. Parameter setting and change are available through PC.

### 1.1.1. Interface type of RS485 reference

- Allows the drive to communicate with any other computers.
- Allows connection of up to 31 drives with multi-drop link system.
- Noise-resistant interface

Users can use any kind of RS232-485 converters. The specifications of converters depend on the manufacturers. Refer to the converter manual for detailed specifications.

### 1.1.2. Before Installation

Before installation and operation, this manual should be read thoroughly. If not, it can cause personal injury or damage other equipment.

## 2. SPECIFICATION

### 2.1. Performance specification

Items	Specifications
Communication method	RS485 (Using RS232-485 Converter)
Transmission form	Bus method, Multi-drop Link System
Applicable inverter	IS5/iH series drive
Number of drives	Maximum 31 drives connectable
Transmission distance	Max. 1200m (Less than 700 m recommended)
Converter	RS232-485, Use PC with RS232 card embedded

### 2.2. Hardware Specifications

Items	Specifications	
Installation	Option connector on the inverter control board	
Power Supply	Control B/D	5V dc supplied from inverter power supply
	Comm. B/D	Power supplied using 5V DC-DC converter on option board

## 2.3. Communication Specification

Items	Specifications
Communication speed	1200 /2400/4800/9600/19200 bps Selectable
Control procedure	Asynchronous communication system
Communication system	Half duplex system
Character system	BINARY (8 bit)
Stop bit	1 bit
Error check (CRC16)	2 byte
Parity check	None

## 3. PRODUCT DETAIL

### 3.1. Layout and detail

Name	Description		
Connector	Connector to inverter main PCB		
Signal connection terminal	Communication signal connection terminal	P	485 signal - high
		N	485 signal - low
		G	485 Ground
		S	Shield
		T1, T2	Connect a terminating resistor

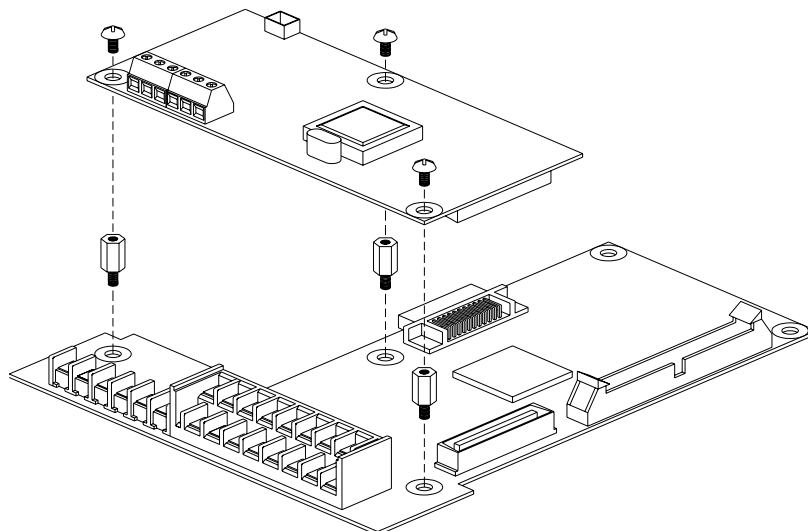

Figure 1-1. Installing RS485 Option Card to SV-iS5

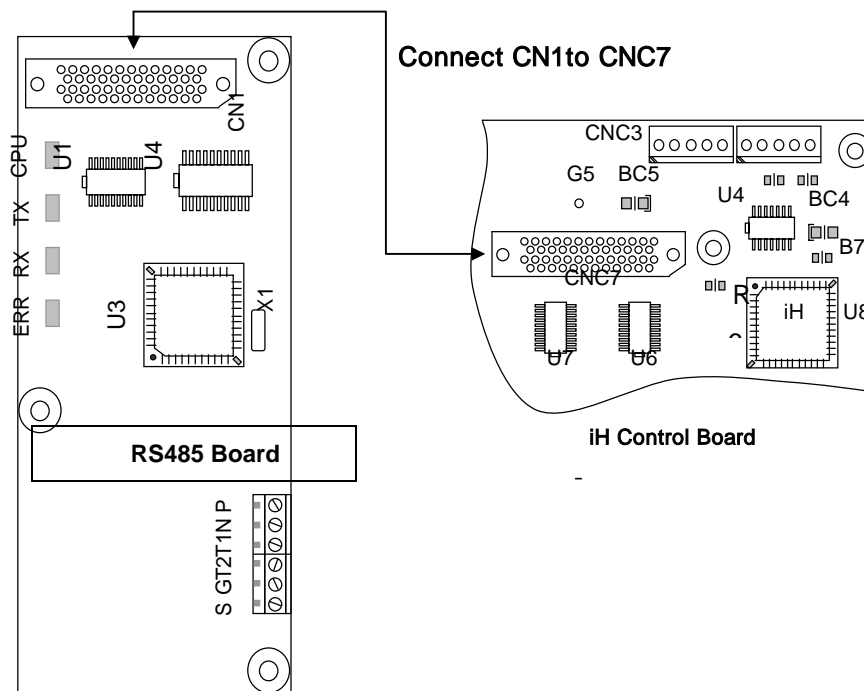

Figure 1-2. Installing RS485 Option Card to SV-iH

### 3.2. Status LED

CPU LED	Normal operation of the board	
RXD LED	Receiving 485 signal	
TXD LED	Responding to 485 signal	
ERR LED	Intermittent blinking	Wrong data received (normal)
	Blinking with CPU LED coincidentally	DPRAM Communication Error
	Blinking after CPU LED blinks	Network Connection TimeOut

## 4. INSTALLATION

### 4.1. Option board installation guide

1. Remove the keypad on the inverter and connect the RS485 option board (See the Figure 1).
2. Double check the board is firmly installed to the board and then apply the inverter power.
3. When power ON, CPU LED is blinking per second after all LEDs blink one after another.
4. If "CPU LED" is not blinking, turn off the inverter power swiftly (if not, inverter and the board may get damaged.) and check for the proper installation of the board. If the problem persists, contact LG distributor.
5. Check I/O 47 is set to "RS485".
6. When the above condition is met, set the communication parameters as shown below.

#### [For SV-iS5]

Parameter code	Display	Setting Value
< COM-01 >	Opt B/D	RS485 displayed automatically
< COM-02 >	Opt mode	Setting command to be controlled by option
< I/O- 46 >	Inv. number	1 ~ 31 (Verify the assigned number is not duplicated.)
< I/O- 47 >	Baud-rate	9600 bps (Factory default)
< I/O- 48 >	Lost command (Note 1)	User defined
< I/O- 49 >	Time.Out (Note 1)	0.1 sec (Factory default)

Note1) set for emergency stop of the inverter when inverter and master communication becomes faulty. Activates when communication has not been made during setting time. This means remote controlling of inverter has not executed. Set these for safe use of the inverter.

#### [For SV-iH]

Parameter code	Display	Setting Value
< FUN-01 >	Freq. set	"Remote"
< FUN-02 >	Run/stop set	"Remote"
< I/O- 50 >	Inv. number	1 ~ 31 (Verify the assigned number is not duplicated.)
< I/O- 51 >	Baud-rate	9600 bps (Factory default)
< I/O- 52 >	Comm.timeout(Note1)	10.0 (Factory default)

Note1) set for emergency stop of the inverter when inverter and master communication becomes faulty. Activates when communication has not been made during setting time. This means remote controlling of inverter has not executed. Set these for safe use of the inverter.

If Comm. Timeout is set to "0", inverter maintains its status without stopping at the event of network communication disconnection.

7. Turn off the inverter power to connect the converter when step 6 is finished.
8. Connect the terminating resistor at the end of network (See the figure 3).

**4.2. RS232-485 converter installation**

See the converter manual for accurate installation.

**4.3. Computer, Converter and RS485 Option Card Configuration**

**4.3.1. System configuration**

- Maximum cable length is 1200m but recommended length is within 700.
- The number of connectable inverter is 31.

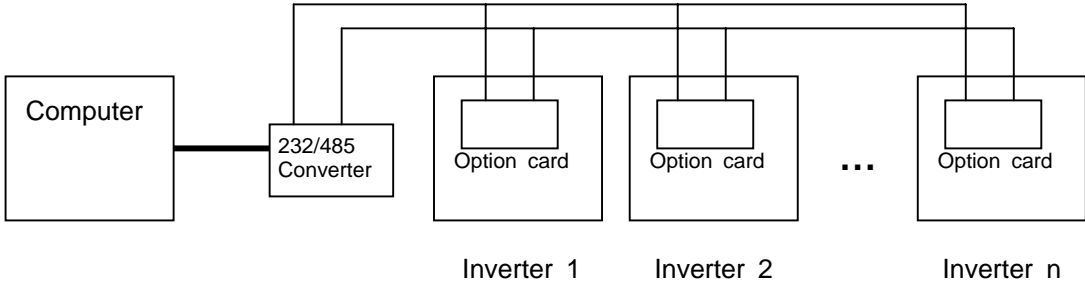

Figure 2. System configuration

**4.3.2. Communication signal connection**

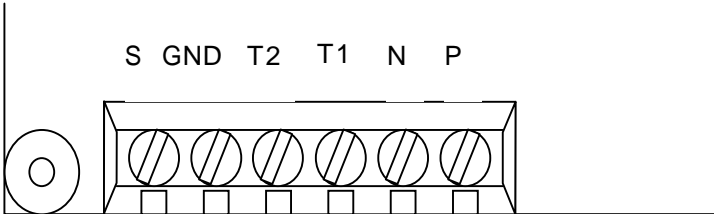

Figure 3. Option card terminal layout

Pin	S	GND	T1	T2	N	P
Description	Shield	Ground	Termination		Signal	

- \* S: Networkd line ground shoud be done only one point.  
Connect it to screw near terminal shield when grounding through inverter.
- \* GND: Ground terminal for 485 communication
- \* T1, T2: Shorting these terminals connects a terminating resistor.

## 5. COMMUNICATION PROTOCOL

- Use LG RS485 protocol (Open protocol). Contact LG representatives.
- Computer or other hosts can be Master and inverters Slave. Inverter responds to Read/Write command from Master.

### 5.1. Supported command codes

Function Code	Name
'R'	Parameter Read
'W'	Parameter Write
'X'	Monitor Register
'Y'	Monitor Execution

(Important: Use ASCII CODE (Capital Letter).)

### 5.2. BroadCast Function

- Use it to send command to all inverters at the network.
- All inverters respond when command is sent from Station # 255.

### 5.3. Error Code

Error Code	Display	Description
ILLEGAL FUNCTION	IF	Invalid command received.
ILLEGAL DATA ADDRESS	IA	Invalid parameter address received. Monitor executed without resistoring monitor.
ILLEGAL DATA VALUE	ID	Invalid data received.
WRITE MODE ERROR	WM	Read Only or not-programmable during run.
FRAME ERROR	FE	Frame size, internal Num or Sum is different.
TIME OUT ERROR	TO	DPRAM communication failed for the set time.
DPRAM OFF LINE	DO	DPRAM is Off-line.
INVALID ID NUMBER	IN	Different address received.
UNDEFINED CONDITION	UC	Undefined condition received.



## 6. TROUBLESHOOTING

Refer to this section when communication error occurs.

- CPU LED does not work properly.

Symptom	Inverter doesn't work properly or connection between options of VFD is not achieved correctly.
Solution	1. Check power source of Inverter. 2. Check connection status whether option card is correctly inserted into the slot of inverter or not, if inverter works normally.

- TXD LED and RXD LED do not work properly.

What to check	Corrective action
Is the power provided to the converter?	Provide electric power to the converter.
Are the connections between converter and computer correct?	Refer to converter manual.
Is communication card installed into the inverter correctly?	Install it correctly referring to "4.Installation"
Is communication program running on the computer?	Start communication program.
Is baud rate of computer and inverter correctly set?	Set baud rate identically referring to "4. Installation"
Is the format of user program* right?	Correct user program.
Is the connection between converter and communication card right?	Connect correctly referring to "4. Installation"

\* User program is User-made S/W for PC.

- ERR LED is blinking.

Status	Solution
Blinking intermittently	Normal operation. Wrong data is received due to noise and other causes.
Blinking after CPU LED blinks	Network communication is not made for TimeOut (I/O 49). Check Master status.
Blinking with CPU LED at the same time	Communication error between inverter and option card. Cycle the inverter power (On/Off). If this problem persists, contact LG representatives.

\* Refer to COM group parameters for Freq/Run/Stop command setting.

## 7. PARAMETER CODE (HEX)

<Common>: Area accessible regardless of inverter models (Note 2)

Parameter Address	Parameter Name	Unit	Read/Write	Data Value (Hex)
0000	Inverter model	-	R	4: SV-iS5 3:SV-IH
0001	Inverter capacity	-	R	SV-iS5 0: 0.75 1:1.5 2:2.2 3: 3.7 4: 5.5 5: 7.5 6: 11 7: 15 8: 18.5 9: 22 A: 30 B:37 C:45 D: 55 E: 75 F: 90 10: 110 11: 132 12: 160 13: 200 14: 220 15: 280 16:375 (Unit: kW)
				SV-IH A: 30 B: 37 C: 45 D: 55 E: 75 F: 90 10: 110 11: 132 12: 160 14: 220 (Unit: kW)
0002	Inverter Input Voltage	-	R	0: 220V 1: 440V
0003	S/W Version	-	R	SV-iS5 0100: Ver. 1.00, 0101: Ver 1.01 SV-iH 0200 : Ver. 2.00, 0201: Ver. 2.01
0004	Parameter Lock	-	R/W	0: Lock (default) 1: Unlock
0005	Frequency Reference	0.01Hz	R/W	0-60000
0006	Run Command	-	R/W	Bit 0: Stop Bit 1: Forward Run Bit 2: Reverse Run Bit 3: Fault Reset Bit 4: Emergency Stop (Bit 0 also resets fault)
0007	Acceleration Time	0.1 sec	R/W	
0008	Deceleration Time	0.1 sec	R/W	
0009	Output Current	0.1 A	R	
000A	Output Frequency	0.01 Hz	R	
000B	Output Voltage	0.1 V	R	
000C	DC Link Voltage	0.1 V	R	
000D	Output Power	0.1 kW	R	

Parameter Address	Parameter Name	Unit	Read/Write	Data Value (Hex)
000E	Sequence Monitor	-	R	SV-iS5 Bit 0: Stop, Bit 1: Forward Running Bit 2: Reverse Running Bit 3:Fault (Trip) Bit 4: Accelerating Bit 5: Decelerating Bit 6: Output Frequency Arrival Bit 7:DC Braking, Bit 8: Stopping Bit 9: Not used Bit10: BrakeOpen Bit 11: FWD Run Command ON, Bit 12: REV Run command ON, Bit13: Rem. Run/Stop Bit14: Rem. Freq. Cmd
				SV-iH BIT 0 : Stop BIT 1 : Forward Run BIT 2 : Reverse Run BIT 3 : Fault (Trip) BIT 4 : Accelerating BIT 5 : Decelerating BIT 6 : Output Frequency Arrival BIT 7 : DC Braking BIT 8 : Stopping BIT13: Rem. Run/Stop BIT 14: Rem. Freq. Cmd
000F	Trip information	-	R	SV-iS5 Bit 0:OCT1,Bit 1: OV, Bit 2: EXT-A Bit 3: BX, Bit 4:OCT2, Bit 5: GF, Bit 6: OH,Bit 7: ETH, Bit 8: OLT, Bit 9: HW-diag,Bit10:EXT-B,Bit11:FO Bit12:OPT,Bit13:POBit,14:IOLT, Bit15:LV SV-iH Bit 0: OC Bit 1: OV Bit 2:EXT Bit 3: BX Bit 4:LV Bit 5:FUSE OPEN Bit 6: GF Bit 7: OH Bit 8: ETH Bit 9:OLT Bit 10: MCF Bit 12: SCT Bit 15: IOLT

Parameter Address	Parameter Name	Unit	Read/Write	Data Value (Hex)
0010	Input Terminal Status	-	R	SV-iS5 Bit 0: P1, Bit 1: P2, Bit 2: P3 Bit 3: P4, Bit 4: P5, Bit 5: P6, Bit 6: RST, Bit 7: BX, Bit 8: JOG, Bit 9: FX, Bit 10: RX SV-iH Bit 0: FX Bit 1:RX Bit 2:BX Bit 3: RST Bit 8: P1 Bit 9: P2 Bit 10: P3 Bit 11: P4 Bit 12: P5 Bit 13: P6
0011	Output Terminal Status	-	R	Bit 0: Q1 (OC1) , Bit 1: Q2 (OC2) Bit 2: Q3 (OC3) SV-iS5 Bit 3: AUX Bit 4: 30AC SV-iH Bit 3: AUX1 Bit 4: AUX2
x0012	V1	-	R	SV-iS5 0 – FFC0 SV-iH 0-FFFF
0x0013	V2	-	R	SV-iS5 0 – FFC0 SV-iH 0-FFFF
0x0014	I	-	R	SV-iS5 0 – FFC0 SV-iH 0- FFFF
0x0015	RPM	-	R	

(Note 2) The changed value in Common affects the current setting but returns to the previous setting when power is cycled or Inverter is reset. However, changing value is immediately reflected in other parameter groups even in the case of Reset or Power On/Off.

**SV-IS5**

## &lt; DRV group &gt;

Address	NO.	Description	Default	Maximum	Minimum	Unit
5100	DRV#00	Cmd. freq	0	MaxFreq	0	0.01Hz
5101	DRV#01	Acc. Time	100	6000	0	0.1sec
5102	DRV#02	Dec. Time	200	6000	0	0.1sec
5103	DRV#03	Drive mode	1	2	0	
5104	DRV#04	Freq. mode	0	4	0	
5105	DRV#05	Step freq - 1	1000	MaxFreq	startFreq	0.01Hz
5106	DRV#06	Step freq - 2	2000	MaxFreq	startFreq	0.01Hz
5107	DRV#07	Step freq - 3	3000	MaxFreq	startFreq	0.01Hz
5108	DRV#08	Current	-	-	-	0.1A
5109	DRV#09	Speed	-	-	-	1rpm
510A	DRV#10	DC Link Voltage		-	-	V

## &lt; FU1 group &gt;

Address	NO.	Description	Default	Maximum	Minimum	Unit
5203	FU1 #03	Run prohibit	0	2	0	
5205	FU1 #05	Acc. pattern	0	4	0	
5206	FU1 #06	Dec. pattern	0	4	0	
5207	FU1 #07	Stop mode	0	2	0	
5208	FU1 #08	DcBr freq.	500	6000	startFreq	0.01Hz
5209	FU1 #09	DcBlk time	10	6000	0	0.01sec
520A	FU1 #10	DcBr value	50	200	0	%
520B	FU1 #11	DcBr time	10	600	0	0.1sec
520C	FU1 #12	DcSt value	50	200	0	%
520D	FU1 #13	DcSt time	0	600	0	0.1sec
5214	FU1 #20	Max freq.	6000	40000	4000	0.01Hz
5215	FU1 #21	Base freq.	6000	maxFreq	3000	0.01Hz
5216	FU1 #22	Start freq.	50	6000	1	0.01Hz
5217	FU1 #23	Freq limit	0	1	0	
5218	FU1 #24	F-limit Lo.	50	highFreq	startFreq	0.01Hz
5219	FU1 #25	F-limit Hi.	6000	maxFreq	lowFreq	0.01Hz
521A	FU1 #26	Torque boost	0	1	0	
521B	FU1 #27	Fwd boost	20	150	0	0.1%
521C	FU1 #28	Rev boost	20	150	0	0.1%
521D	FU1 #29	V/F pattern	0	2	0	
521E	FU1 #30	User freq. 1	1500	maxFreq	0	0.01Hz

Address	NO.	Description	Default	Maximum	Minimum	Unit
521F	FU1 #31	User volt. 1	25	100	0	%
5220	FU1 #32	User freq. 2	3000	maxFreq	0	0.01Hz
5221	FU1 #33	User volt. 2	50	100	0	%
5222	FU1 #34	User freq. 3	4500	maxFreq	0	0.01Hz
5223	FU1 #35	User volt. 3	75	100	0	%
5224	FU1 #36	User freq. 4	6000	maxFreq	0	0.01Hz
5225	FU1 #37	User volt. 4	100	100	0	%
5226	FU1 #38	Volt control	1000	1100	400	0.1%
5227	FU1 #39	Energy save	0	30	0	%
5232	FU1 #50	ETH select	0	1	0	
5233	FU1 #51	ETH 1min	180	200	ETH Cont	%
5234	FU1 #52	ETH Cont	100	150	50	%
5235	FU1 #53	Motor type	0	1	0	
5236	FU1 #54	OL level	150	150	30	%
5237	FU1 #55	OL time	100	300	0	0.1sec
5238	FU1 #56	OLT select	1	1	0	
5239	FU1 #57	OLT level	180	200	30	%
523A	FU1 #58	OLT time	600	600	0	0.1sec
523B	FU1 #59	Stall prev.	0	7	0	
523C	FU1 #60	Stall level	180	250	30	%

< FU2 group >

Address	NO.	Description	Default	Maximum	Minimum	Unit
5307	FU2 #07	Dwell freq	500	maxFreq	StartFreq	0.01Hz
5308	FU1 #08	Dwell time	0	100	0	0.1sec
530A	FU2 #10	Jump freq	0	1	0	
530B	FU2 #11	jump lo 1	1000	jump Hi [0]	StartFreq	0.01Hz
530C	FU2#12	jump Hi 1	1500	maxFreq	jump Lo[0]	0.01Hz
530D	FU2 #13	jump lo 2	2000	jump Hi [1]	StartFreq	0.01Hz
530E	FU2 #14	jump Hi 2	2500	maxFreq	jump Lo[1]	0.01Hz
530F	FU2 #15	jump lo 3	3000	jump Hi [2]	StartFreq	0.01Hz
5310	FU2 #16	jump Hi 3	3500	maxFreq	jump Lo[2]	0.01Hz
5311	FU2 #17	Start Curve	40	100	1	%
5312	FU2 #18	End Curve	40	100	1	%
5313	FU2 #19	Trip select	0	3	0	BIT
5314	FU2 #20	Power-on run	0	1	0	

Address	NO.	Description	Default	Maximum	Minimum	Unit
5315	FU2 #21	RST restart	0	1	0	
5316	FU2 #22	Speed Search	0	15	0	BIT
5317	FU2 #23	SS Sup-Curr	100	200	80	
5318	FU2 #24	SS P-gain	100	9999	0	
5319	FU2 #25	SS I-gain	1000	9999	0	
531A	FU2 #26	Retry number	0	10	0	
531B	FU2 #27	Retry delay	10	600	0	0.1sec
531E	FU2#30	Motor select	0	9	0	
531F	FU2#31	Pole number	4	12	2	
5320	FU2 #32	Rated-Slip	200	1000	0	0.01Hz
5321	FU2 #33	Rated-Curr	36	2000	10	0.1A
5322	FU2 #34	Noload-Curr	7	2000	5	0.1A
5324	FU2 #36	Efficiency	72	100	70	%
5325	FU2 #37	Inertia rate	0	1	0	
5327	FU2 #39	Carrier freq	50	150	10	0.1kHz
5328	FU2 #40	Control mode	0	2	0	
5329	FU2 #41	Auto tuning	0	1	0	
532A	FU2 #42	Rs (Note 4)	(Note 3)	5000	0	0.001ohm
532B	FU2 #43	Rr (Note 5)	(Note 3)	5000	0	0.001ohm
532C	FU2 #44	Lsigma (Note 6)	(Note 3)	MaxInduc	0	0.001mH
532D	FU2 #45	SL P-gain	32767	32767	0	
532E	FU2 #46	SL I-gain	3276	32767	0	
532F	FU2 #47	proc PI mode	0	1	0	
5330	FU2 #48	PID Ref	1	1	0	
5331	FU2 #49	PID Ref Mode	0	5	0	
5332	FU2 #50	PID Out Dir	1	1	0	
5333	FU2 #51	PID F/B	0	2	0	
5334	FU2 #52	PID P-gain	3000	9999	0	0.1%
5335	FU2 #53	PID I-time	300	320	0	0.1sec
5336	FU2 #54	PID D-time	0	9999	0	0.1msec
5337	FU2 #55	PID +limit	6000	maxFreq	0	0.01Hz
5338	FU2 #56	PID -limit	6000	maxFreq	0	0.01Hz
5339	FU2 #57	PID Out Inv	0	1	0	
533A	FU2 #58	PID OutScale	1000	9999	1	0.1%
533B	FU2 #59	PID P2-gian	1000	9999	0	0.1%
533C	FU2 #60	P-gain Scale	1000	1000	0	0.1%
5345	FU2 #69	Acc/Dec ch F	0	maxFreq	0	0.01Hz

Address	NO.	Description	Default	Maximum	Minimum	Unit
5346	FU2 #70	Acc/Dec freq	0	1	0	
5347	FU2 #71	Time scale	1	2	0	
5348	FU2 #72	PowerOn disp	0	12	0	
5349	FU2 #73	User disp	0	2	0	
534A	FU2 #74	RPM factor	100	1000	1	%
534B	FU2 #75	DB mode	1	2	0	
534C	FU2 #76	DB %ED	10	30	0	%
534F	FU2 #79	S/W Debug02	0	1	0	
5351	FU2 #81	2nd Acc time	50	6000	0	0.1sec
5352	FU2 #82	2nd Dec time	100	6000	0	0.1sec
5353	FU2 #83	2nd BaseFreq	6000	maxFreq	3000	0.01Hz
5354	FU2 #84	2nd V/F	0	2	0	
5355	FU2 #85	2nd F-boost	20	150	0	0.1%
5356	FU2 #86	2nd R-boost	20	150	0	0.1%
5357	FU2 #87	2nd Stall	150	150	30	%
5358	FU2 #88	2nd ETH 1min	150	200	2nd ETH Cont	%
5359	FU2 #89	2nd ETH Cont.	100	2nd ETH 1min	50	%
535A	FU2 #90	2nd R-Curr	36	2000	10	0.1A
538D	FU2 #93	Para. Init	0	8	0	

(Note 3,4,5,6) Value depends on motor capacity.

< I/O group >

Address	NO.	Description	Default	Maximum	Minimum	Unit
5401	I/O #01	V1 filter	10	9999	0	ms
5402	I/O #02	V1 volt x1	0	V1 vort x2	0	0.01V
5403	I/O #03	V1 freq y1	0	maxFreq	0	0.01Hz
5404	I/O #04	V1 volt x2	1000	1000	V1 volt x1	0.01V
5405	I/O #05	V1 freq y2	6000	maxFreq	0	0.01Hz
5406	I/O #06	I filter	10	9999	0	ms
5407	I/O #07	I curr x1	400	I curr x2	0	0.01mA
5408	I/O #08	I freq y1	0	maxFreq	0	0.01Hz
5409	I/O #09	I curr x2	2000	2000	I curr x1	0.01mA
540A	I/O #10	I freq y2	6000	maxFreq	0	0.01Hz



Address	NO.	Description	Default	Maximum	Minimum	Unit
540B	I/O #11	Wire broken	0	2	0	
540C	I/O #12	P1 define	0	32	0	
540D	I/O #13	P2 define	1	32	0	
540E	I/O #14	P3 define	2	32	0	
5411	I/O #17	Ti Filt Num	15	50	2	
5414	I/O #20	Jog freq	1000	MaxFreq	startFreq	0.01Hz
5415	I/O #21	Step freq - 4	4000	MaxFreq	startFreq	0.01Hz
5416	I/O #22	Step freq - 5	5000	MaxFreq	startFreq	0.01Hz
5417	I/O #23	Step freq - 6	4000	MaxFreq	startFreq	0.01Hz
5418	I/O #24	Step freq - 7	3000	MaxFreq	startFreq	0.01Hz
5419	I/O #25	Acc time- 1	200	6000	0	0.1sec
541A	I/O #26	Dec time - 1	200	6000	0	0.1sec
541B	I/O #27	Acc time - 2	300	6000	0	0.1sec
541C	I/O #28	Dec time - 2	300	6000	0	0.1sec
541D	I/O #29	Acc time - 3	400	6000	0	0.1sec
541E	I/O #30	Dec time - 3	400	6000	0	0.1sec
541F	I/O #31	Acc time - 4	500	6000	0	0.1sec
5420	I/O #32	Dec time - 4	500	6000	0	0.1sec
5421	I/O #33	Acc time - 5	400	6000	0	0.1sec
5422	I/O #34	Dec time - 5	400	6000	0	0.1sec
5423	I/O #35	Acc time - 6	300	6000	0	0.1sec
5424	I/O #36	Dec time - 6	300	6000	0	0.1sec
5425	I/O #37	Acc time - 7	200	6000	0	0.1sec
5426	I/O #38	Dec time - 7	200	6000	0	0.1sec
5428	I/O #40	FM mode	0	3	0	
5429	I/O #41	FM adjust	100	200	10	%
542A	I/O #42	FDT freq	3000	maxFreq	0	0.01Hz
542B	I/O #43	FDT band	1000	maxFreq	0	0.01Hz
542C	I/O #44	Aux mode	12	23	0	
542D	I/O #45	Relay mode	2	7	0	BIT3
542E	I/O #46	Inv No.	1	31	1	
542F	I/O #47	Baud rate	3	4	0	
5430	I/O #48	Lost command	0	2	0	
5431	I/O #49	Time out	10	1200	1	0.1sec

\* Contact LG representatives if address for Auto sequence operation parameters is needed.

< EXT group >

Address	NO.	Description	Default	Maximum	Minimum	Unit
5501	EXT #01	Sub B/D				
5502	EXT #02	P4 define	3	32	0	
5503	EXT #03	P5 define	4	32	0	
5504	EXT #04	P6 define	5	32	0	
5505	EXT #05	V2 mode	0	2	0	
5506	EXT #06	V2 filter	10	9999	0	msec
5507	EXT #07	V2 volt x1	0	V2 volt x2	0	0.01V
5508	EXT #08	V2 freq y1	0	maxFreq	0	0.01Hz
5509	EXT #09	V2 volt x2	1000	1000	V2 volt x1	0.01V
550A	EXT #10	V2 freq y2	6000	maxFreq	0	0.01Hz
550E	EXT #14	F mode	0	2	0	
550F	EXT #15	F pulse set	0	1	0	
5510	EXT #16	F pulse num	1024	4096	360	
5511	EXT #17	F filter	10	9999	0	msec
5512	EXT #18	F pulse x1	0	F pulse x2	0	0.1kHz
5512	EXT #18	F pulse x1	0	F pulse x2	0	0.1kHz
5513	EXT #19	F freq y1	0	maxFreq	0	0.01Hz
5514	EXT #20	F pulse x2	100	1000	F pulse x1	0.1kHz
5515	EXT #21	F freq y2	6000	maxFreq	0	0.01Hz
5516	EXT #22	PG P-gain	3000	9999	0	
5517	EXT #23	PG I-gain	300	9999	0	
5518	EXT #24	PG Slip Freq	100	200	0	%
551E	EXT #30	Q1 define	0	23	0	
551F	EXT #31	Q2 define	1	23	0	
5520	EXT #32	Q3 define	2	23	0	
5522	EXT #34	LM mode	1	3	0	
5523	EXT #35	LM adjust	100	200	10	%
5528	EXT #40	AM1 mode	0	3	0	
5529	EXT #41	AM1 adjust	100	200	10	%
552A	EXT #42	AM2 mode	3	3	0	
552B	EXT #43	AM2 adjust	100	200	10	%
553C	EXT #60	SPD P-Gain	10	500	1	
553D	EXT #61	SPD I-Gain	10	500	1	
553E	EXT #62	POS P-gain	10	500	1	
553F	EXT #63	POS I-gain	10	500	1	
5540	EXT #64	Slip limit	500	500	0	0.01Hz
5541	EXT #65	Oper mode	1	4	0	
5542	EXT #66	Enc 0pulse	1000	2000	1000	

Address	NO.	Description	Default	Maximum	Minimum	Unit
5543	EXT #67	Enc 1pulse	1000	2000	1000	
5544	EXT #67	ROT ratio	10	100	1	
5545	EXT #68	STBY ROT	0	1000	0	
5546	EXT #69	STBY SPD	0	4000	0	
5547	EXT #70	POS Sync	10	100	1	
5548	EXT #71	SPD sync	10	20	1	
5549	EXT #72	POS offset	0	9999	0	
554A	EXT #73	User dir	0	1	0	
554B	EXT #74	Max speed	1800	9999	1000	
554C	EXT #75	Motor pulse	1000	2000	500	
554D	EXT #76	DAC0 set	12	99	10	
554E	EXT #77	DAC1 set	24	99	10	
555A	EXT #89	Station ID	1	63	0	

< COM group >

Address	NO.	Description	Default	Maximum	Minimum	Unit
5601	COM #01	Opt B/D				
5602	COM #02	Opt mode	0	3	0	
5603	COM #03	Opt version	1.00			
5604	COM #04	D-in mode	0	6	0	
5605	COM #05	Digital Ftr	15	50	2	
560A	COM #10	MAC ID	63	63	0	
560B	COM #11	Baud rate	0	2	0	
560C	COM #12	Out instance	0	3	0	
560D	COM #13	In instance	0	3	0	
5611	COM #17	Station ID	1	63	0	
5614	COM #20	Profi MAC ID	1	127	1	
561E	COM #30	Output Num	3	8	0	
561F	COM #31	Output 1	10	22527	0	
5620	COM #32	Output 2	14	22527	0	
5621	COM #33	Output 3	15	22527	0	
5622	COM #34	Output 4	0	22527	0	
5623	COM #35	Output 5	0	22527	0	
5624	COM #36	Output 6	0	22527	0	
5625	COM #37	Output 7	0	22527	0	
5626	COM #38	Output 8	0	22527	0	
5628	COM #40	Input Num	2	8	0	
5629	COM #41	Input 1	5	22527	0	
562A	COM #42	Input 2	6	22527	0	
562B	COM #43	Input 3	0	22527	0	
562C	COM #44	Input 4	0	22527	0	
562D	COM #45	Input 5	0	22527	0	
562E	COM #46	Input 6	0	22527	0	
562F	COM #47	Input 7	0	22527	0	
5630	COM #48	Input 8	0	22527	0	
5634	COM #52	Modbus Mode	0	0	0	

\* I/O-46, 47: station number and baud rate setting

COM-01 [Opt B/D]

Displays option board installed.

Automatically set when board is installed.

COM-02 [Opt Mode]

Run/Stop/Frequency Reference setting via Option Board

Value	Display	Description
0	None	Disabled
1	Command	Run/Stop command via Option
2	Freq	Frequency command via Option
3	Cmd + Freq	Run/Stop/Frequency command via Option

Use Common area #0x0005 for Frequency command via Option.

Use Common area #0x0006 for Run/Stop command via Option.

COM-03 [Opt Version]

Displays option card's version.

< APP group >

Address	NO.	Description	Default	Maximum	Minimum	Unit
5701	APP #01	APP mode	0	3	0	
5702	APP #02	Trv. Amp[%]	0	200	0	0.1%
5703	APP #03	Trv. Scr	0	500	0	0.1%
5704	APP #04	Trv Acc Time	20	6000	1	0.1sec
5705	APP #05	Trv Dec Time	30	6000	1	0.1sec
5706	APP #06	Trv Off Hi	0	200	0	0.1%
5707	APP #07	Trv Off Lo	0	200	0	0.1%
5708	APP #08	Aux Mot Run	0	4	0	
5709	APP #09	Starting Aux	1	4	1	
570A	APP #10	Auto Op Time	0	5940	0	
570B	APP #11	Start freq1	4999	maxFreq	0	0.01Hz
570C	APP #12	Start freq2	4999	maxFreq	0	0.01Hz
570D	APP #13	Start freq3	4999	maxFreq	0	0.01Hz
570E	APP #14	Start freq4	4999	maxFreq	0	0.01Hz
570F	APP #15	Stop freq1	1500	maxFreq	0	0.01Hz
5710	APP #16	Stop freq2	1500	maxFreq	0	0.01Hz
5711	APP #17	Stop freq3	1500	maxFreq	0	0.01Hz
5712	APP #18	Stop freq4	1500	maxFreq	0	0.01Hz

Address	NO.	Description	Default	Maximum	Minimum	Unit
5713	APP #19	Aux start DT	600	9999	0	0.1sec
5714	APP #20	Aux stop DT	600	9999	0	0.1sec
5715	APP #21	Nbr Aux'	4	4	0	
5716	APP #22	Regul Bypass	0	1	0	
5717	APP #23	Sleep Delay	600	9999	0	0.1sec
5718	APP #24	Sleep Freq	19	maxFreq	0	0.01Hz
5719	APP #25	WakeUp level	35	100	0	1%
571A	APP #26	AutoCh_Mode	1	2	0	
571B	APP #27	AutoEx intv	4320	5940	0	0.1sec
571C	APP #28	AutoEx level	20	100	0	1%
571D	APP #29	Inter-lock	0	1	0	
571E	APP #30	Actual Value	0	maxFreq	0	0.01Hz
571F	APP #31	Actual Perc	0	100	0	1%
5720	APP #32	Draw mode	0	3	0	
5721	APP #33	DrawPerc	100	150	0	1%

### **SV-iH**

< DRV group >

Address	NO.	Description	Default	Maximum	Minimum	Unit
4001	DRV#01	Acc. time	300	60000	0	0.1sec
4002	DRV#02	Dec. time	600	60000	0	0.1sec
4003	DRV#03	Current	0	1	0	0.1 A
4004	DRV#04	Speed	0	1	0	1 rpm
4005	DRV#05	Power	0	5000	0	0.1kW

< FUN group >

Address	NO.	Description	Default	Maximum	Minimum	Unit
4101	FU1 #01	Freq. Set	0	2	0	
4102	FU1 #02	Run/stop set	0	3	0	
4103	FU1 #03	Run prohibit	0	2	0	
4104	FU1 #04	Freq. Max	6000	40000	4000	0.01Hz
4105	FU1 #05	Freq. base	6000	Freq. max	4000	0.01Hz
4106	FU1 #06	Freq. start	50	500	50	0.01Hz
4107	FU1 #07	Hold time	0	100	0	0.1sec

Address	NO.	Description	Default	Maximum	Minimum	Unit
4108	FU1 #08	V/F pattern	0	3	0	
4109	FU1 #09	Fwd boost	2	20	0	1 %
410A	FU1 #10	Rev boost	2	20	0	1 %
410B	FU1 #11	Acc. pattern	0	2	0	
410C	FU1 #12	Dec. pattern	0	2	0	
410D	FU1 #13	Volt control	100	110	40	1 %
410E	FU1 #14	Energy save	100	100	70	1 %
410F	FU1 #15	Stop mode	0	2	0	
4110	FU1 #16	User-1f	1000	User-2f	0	0.01Hz
4111	FU1 #17	User-1v	15	User-2v	0	1 %
4112	FU1 #18	User-2f	3000	Freq. max	User-1f	0.01Hz
4113	FU1 #19	User-2v	50	100	User-1v	1 %
4114	FU1 #20	V-I mode	0	3	0	
4115	FU1 #21	Filter gain	25	100	1	1 %
4116	FU1 #22	Analog gain	1000	2500	500	0.1 %
4117	FU1 #23	Analog bias	1000	2000	0	0.1 %
4118	FU1 #24	Analog dir	0	1	0	
4119	FU1 #25	Freq. limit	0	1	0	
411A	FU1 #26	F-limit high	6000	Freq. max	F_limit low	0.01Hz
411B	FU1 #27	F-limit low	0	F-limit high	0	0.01Hz
411C	FU1 #28	Freq. jump	0	1	0	
411D	FU1 #29	Freq-jump 1f	1000	Freq. max	0	0.01Hz
411E	FU1 #30	Freq-jump 2f	2000	Freq. max	0	0.01Hz
411F	FU1 #31	Freq-jump 3f	3000	Freq. max	0	0.01Hz
4120	FU1 #32	Freq. band	500	3000	0	0.01Hz
4121	FU1 #33	DC-br freq.	50	6000	0	0.01Hz
4122	FU1 #34	DC-br block	20	50	5	0.1sec
4123	FU1 #35	DC-br time	5	250	1	0.1sec
4124	FU1 #36	DC-br value	1	20	1	1 %
4125	FU1 #37	Slip compen.	0	1	0	
4126	FU1 #38	Rated slip	0	500	0	0.01Hz
4127	FU1 #39	M-rated cur.	1	9990	1	0.1 A
4128	FU1 #40	No-load cur.	1	3000	1	0.1 A
4129	FU1 #41	Inv capacity	0	15	0	
412A	FU1 #42	Retry number	0	10	0	
412B	FU1 #43	Retry time	10	100	0	0.1sec
412C	FU1 #44	Relay mode	0	3	0	

Address	NO.	Description	Default	Maximum	Minimum	Unit
412D	FU1 #45	Stall mode	0	7	0	
412E	FU1 #46	Stall level	150	150	30	1 %
412F	FU1 #47	OL level	150	150	30	1 %
4130	FU1 #48	OL time	100	300	10	0.1sec
4131	FU1 #49	OC lim. level	160	200	30	1 %
4132	FU1 #50	OC lim. time	600	600	0	0.1sec
4133	FU1 #51	ETH select	0	1	0	
4134	FU1 #52	ETH level	150	150	110	1 %
4135	FU1 #53	Motor type	0	1	0	
4136	FU1 #54	Pole number	4	12	2	
4137	FU1 #55	IPF select	0	1	0	
4138	FU1 #56	SS acc. time	50	6000	1	0.1sec
4139	FU1 #57	SS dec. time	100	6000	1	0.1sec
413A	FU1 #58	SS gain	100	200	0	1 %
413B	FU1 #59	RST-restart	0	1	0	
413C	FU1 #60	Power on st	0	1	0	
413D	FU1 #61	Carrier freq	6	Carrier_max	2	1 kHz
413E	FU1 #62	PI-control	0	1	0	
413F	FU1 #63	P-gain	10	30000	1	
4140	FU1 #64	I-gain	50	30000	1	
4141	FU1 #65	PI-fb select	0	2	0	
4142	FU1 #66	PI-fb flt G.	25	100	1	1 %
4143	FU1 #67	PI-fb gain	1000	2500	500	0.1 %
4144	FU1 #68	PI-fb bias	1000	2000	0	0.1 %
4145	FU1 #69	PI-fb dir	0	1	0	
4146	FU1 #70	I_term scale	100	100	1	1 %
4147	FU1 #71	PI error invert	0	1	0	
4148	FU1 #72	Regul bypass	0	1	0	
415E	FU1 #94	CT/VT	0	1	0	

< I/O group >

Address	NO.	Description	Default	Maximum	Minimum	Unit
4201	I/O #01	P1 input	0	14	0	
4202	I/O #02	P2 input	1	14	0	
4203	I/O #03	P3 input	2	14	0	
4204	I/O #04	P4 input	3	14	0	
4205	I/O #05	P5 input	4	14	0	
4206	I/O #06	P6 input	5	14	0	
4207	I/O #07	OC1 output	11	12	0	
4208	I/O #08	OC2 output	12	12	0	
4209	I/O #09	OC3 output	13	12	0	
420A	I/O #10	AUX1 output	10	12	0	
420B	I/O #11	AUX2 output	10	12	0	
420C	I/O #12	Jog freq.	3000	Freq. max	0	0.01 Hz
420D	I/O #13	Step freq-1	1000	Freq. max	0	0.01 Hz
420E	I/O #14	Step freq-2	2000	Freq. max	0	0.01 Hz
420F	I/O #15	Step freq-3	3000	Freq. max	0	0.01 Hz
4210	I/O #16	Step freq-4	4000	Freq. max	0	0.01 Hz
4211	I/O #17	Step freq-5	5000	Freq. max	0	0.01 Hz
4212	I/O #18	Step freq-6	4600	Freq. max	0	0.01 Hz
4213	I/O #19	Step freq-7	3700	Freq. max	0	0.01 Hz
4214	I/O #20	Acc time-1	10	60000	0	0.01 Hz
4215	I/O #21	Dec time-1	10	60000	0	0.01 Hz
4216	I/O #22	Acc time-2	20	60000	0	0.01 Hz
4217	I/O #23	Dec time-2	20	60000	0	0.01 Hz
4218	I/O #24	Acc time-3	30	60000	0	0.01 Hz
4219	I/O #25	Dec time-3	30	60000	0	0.01 Hz
421A	I/O #26	Acc time-4	40	60000	0	0.01 Hz
421B	I/O #27	Dec time-4	40	60000	0	0.01 Hz
421C	I/O #28	Acc time-5	50	60000	0	0.01 Hz
421D	I/O #29	Dec time-5	50	60000	0	0.01 Hz
421E	I/O #30	Acc time-6	60	60000	0	0.01 Hz
421F	I/O #31	Dec time-6	60	60000	0	0.01 Hz
4220	I/O #32	Acc time-7	70	60000	0	0.01 Hz
4221	I/O #33	Dec time-7	70	60000	0	0.01 Hz
4222	I/O #34	LM meter	0	1	0	
4223	I/O #35	LM adj.	100	120	0	1 %
4224	I/O #36	FM adj.	100	120	0	1 %



Address	NO.	Description	Default	Maximum	Minimum	Unit
4225	I/O #37	lo adj	100	120	0	1 %
4226	I/O #38	FST-freq.	50	Freq. max	50	0.01 Hz
4227	I/O #39	FDT-freq.	6000	Freq. max	50	0.01 Hz
4228	I/O #40	FDT-band	100	3000	0	0.01 Hz
4229	I/O #41	Mul. factor	100	999	0	
422A	I/O #42	Div. factor	100	999	1	
4232	I/O #50	Inv. Number	1	31	1	
4233	I/O #51	Baud-rate	3	4	0	
4234	I/O #52	Comm. timeout	10	600	0	0.1 sec
423A	I/O #58	DI mode	1	2	0	
423B	I/O #59	DA mode	0	2	0	
423C	I/O #60	DA adj.	100	120	80	1 %
423D	I/O #61	FN : St. ID	1	63	1	
423E	I/O #62	DN : MAC ID	1	63	0	
423F	I/O #63	DN : BaudRate	0	2	0	
4240	I/O #64	DN : Out Inst	0	3	0	
4241	I/O #65	DN : In Inst	0	3	0	



**LG**



**LG Industrial Systems Co., Ltd.**

LGIS constantly endeavors to improve its product so that information in this manual is subject to change without notice.

**Visit Our Website:** <http://www.lgis.com/>

December 23, 2002  
Publication #: 10310000414