

Modbus TCP Option Board SV-iS7 Series



- * Use this board after read Safety Instruction of this manual carefully before using and follow the instructions exactly.
- * Please hand this user manual to end user and trouble shooting manager
- * After read this manual, keep it at handy for future reference.

Before using the product, thank you for using our Modbus/TCP option board.

Safety Instruction

- To prevent injury and danger in advance for safe and correct use of the product, be sure to follow the Safety Instructions.

- The instructions are divided as 'WARNING' and 'CAUTION' which mean as follow.



WARNING

This symbol indicates the possibility of death or serious injury.



CAUTION

This symbol indicates the possibility of injury or damage to property.

- The meaning of each symbol in this manual and on your equipment is as follows.



This is the safety alert symbol.



This is the dangerous voltage alert symbol.

- After reading the manual, keep it in the place that the user always can Contact easily.
- Before you proceed, be sure to read and become familiar with the safety precautions at the beginning of this manual. If you have any questions, seek expert advice before you proceed. Do not proceed if you are unsure of the safety precautions or any procedure.



WARNING

- **Be cautious about dealing with CMOS elements of option board.**

It can cause malfunction by static electricity.

- **Connection changing like communication wire change must be done with power off.**

It can cause communication faulty or malfunction.

- **Be sure to connect exactly between Inverter and option board.**

It can cause communication faulty or malfunction.

- **Check parameter unit when setting parameter.**

It can cause communication faulty

1. Introduction

Modbus/TCP communication board make SV-iS7 be connected to Ethernet network. Controlling and monitoring of inverter can be done by PLC sequence program or any Master Module. Since Ethernet which constitutes Internet has been used and IPv4 has been supported, wherever Internet can be done, controlling and monitoring is possible. But, Ethernet network of the factory has to be connected to Internet through Gateway.

With simple wiring, installation time can be reduced and maintenance becomes easier.

2. Modbus/TCP Technical features

Transmission Speed	10Mbps, 100Mbps
Transmission method	Baseband
Max. extended distance between nodes.	100m (Node-Hub)
Max. node number	Hub connection
Auto Negotiation	Supported
Max. Frame size	1500 bytes
Communication zone access method	CSMA/CD
Frame error checking method	CRC32
Recommended connecting channel	3 channels

3. Product Constituents

- Modbus TCP communication board: 1
- Modbus TCP manual: 1
- Fixed Screw (M3): 1

4. Modbus/TCP Appearance and Installation

(1) Appearance

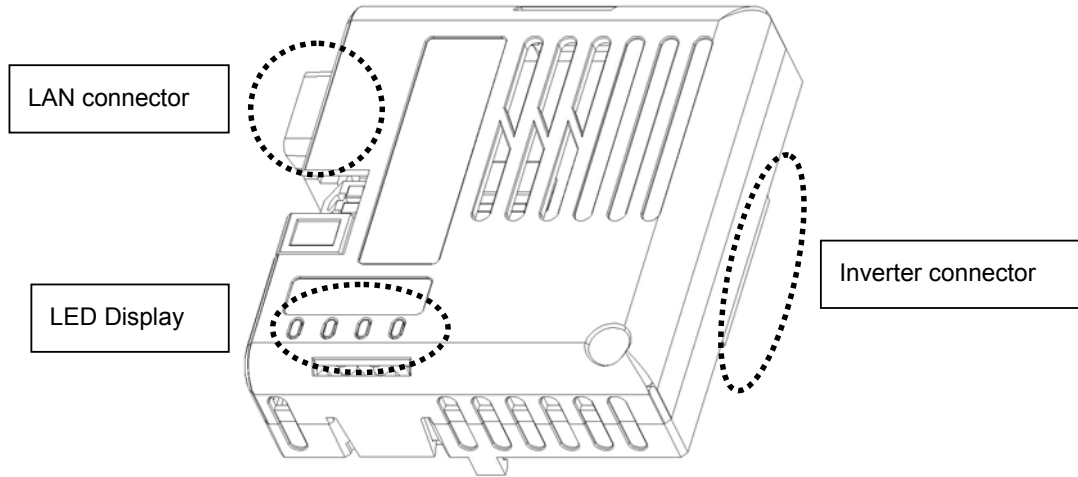

(2) Exterior

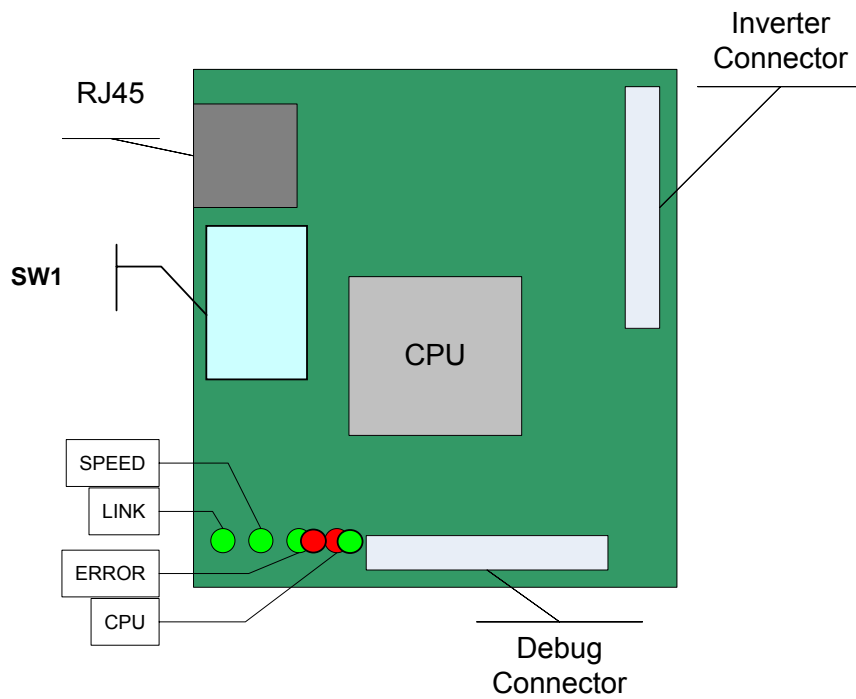

- ▶ **SW1 : Protocol selecting switch**
- . Not used anymore

(3) Communication board connection to iS7 inverter

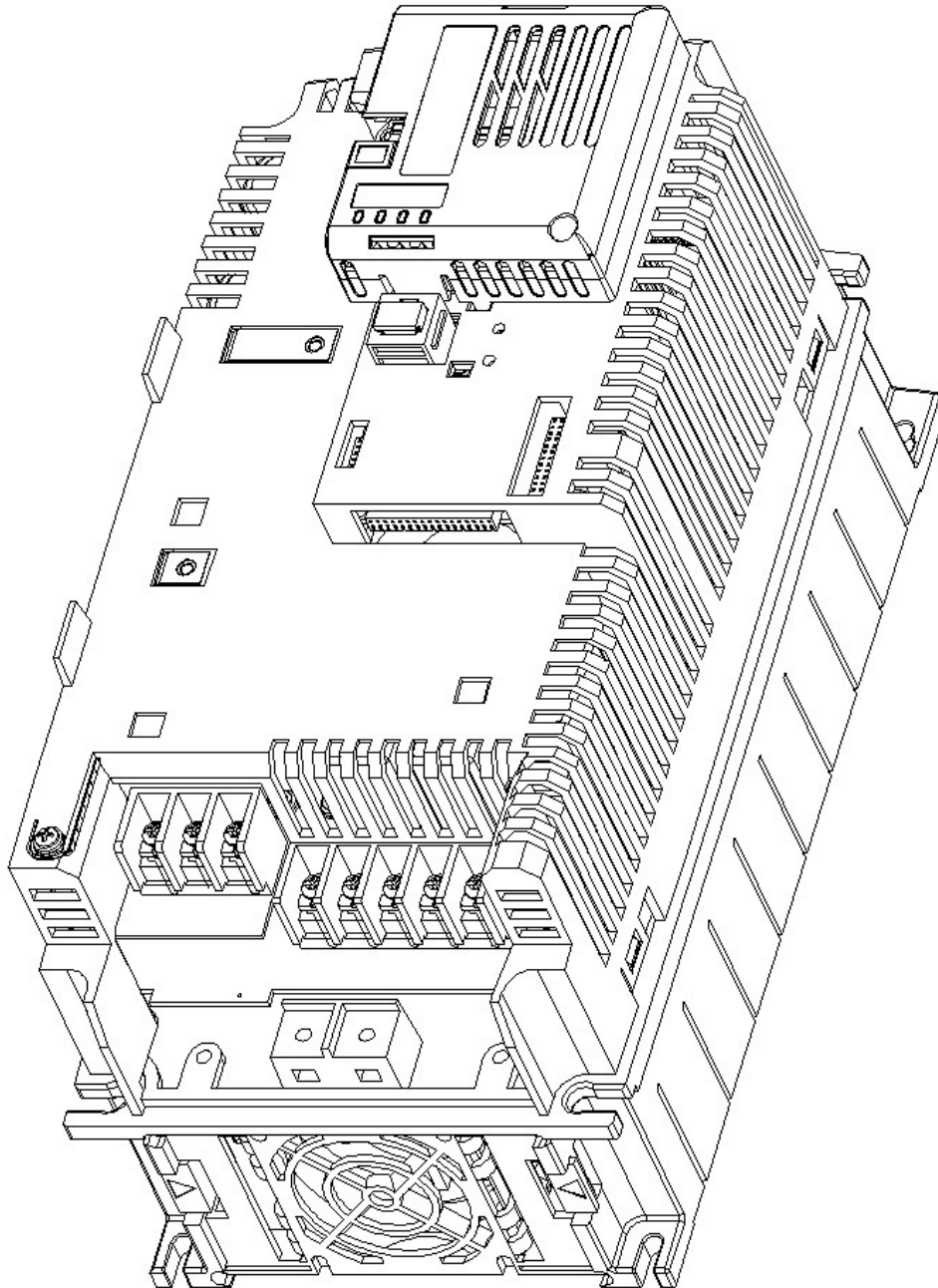

5. Network connection

Communication cable connecting terminal

Pin No.	Signal	Description	Cable color
1	TX+	Transmitting data Plus	White / Yellow
2	TX-	Transmitting data Minus	Yellow
3	RX+	Receiving data Plus	White / Green
4	NONE	Not used	Blue
5	NONE	Not used	White / Blue
6	RX-	Receiving data Minus	Green
7	NONE	Not used	White / Brown
8	NONE	Not used	Brown

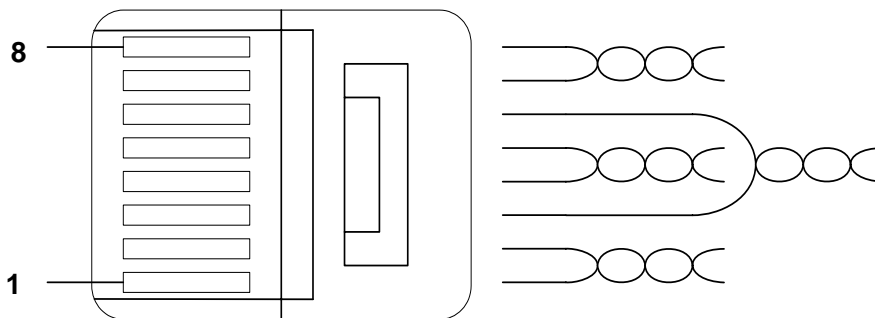

- ※ Make sure that cables connected to Pin1 and 2 are twisted together.
- ※ Make sure that cables connected to Pin3 and 6 are twisted together.

6. Network Cable Standard

(1) Used Frequency band

Category 5 is used. Transmitting speed of category 5 is 100MHz and possible up to 100Mbps.

(2) Twisted Pair cable type

Classification	Detail	Used
UTP (U.UTP)	High speed signal cable with no cover	Maximum 200MHz Voice + Information(Data)+ Low Video signal
FTP (S.UTP)	Cable core covered only	Maximum 100MHz Electromagnetic interruption (EMI) or electric stability considered Voice+ Information (Data) + Low Video (Video) signal
STP (S.STP)	Double-covered, separately covered Pair with cable core covered	Maximum 500MHz Voice +Information(Data)+ Video signal 75Ω coaxial cable replacement

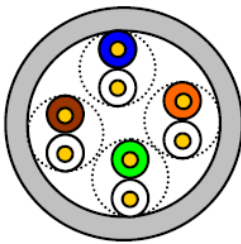

UTP

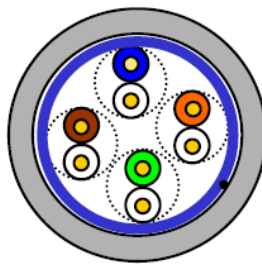

FTP

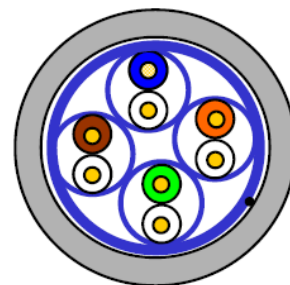

STP

7. Modbus/TCP related Keypad parameter

Inverter parameters below display Modbus/TCP related information.

iS7 Modbus/TCP related Keypad Parameter				
Code number	Parameter name	Initial value	Setting value	Description
CNF-30	Option-1 Type	-	-	Communication card installed in inverter is displayed. (If Modbus/TCP comm. Card is installed, "Ethernet" is displayed)
COM-06	FBus S/W Ver	-	-	The version of Communication card installed in inverter is displayed.
COM-09	FBus Led			LED ON/OFF information in Modbus/TCP communication card is displayed.
COM-10	Opt Parameter1	0x0000	0x0000 ~0xFFFF	Set IP Address.
COM-11	Opt Parameter2	0x0000	0x0000 ~0xFFFF	
COM-12	Opt Parameter3	0x0000	0x0000 ~0xFFFF	Set Subnet Master
COM-13	Opt Parameter4	0x0000	0x0000 ~0xFFFF	
COM-14	Opt Parameter5	0x0000	0x0000 ~0xFFFF	Set Gateway Address.
COM-15	Opt Parameter6	0x0000	0x0000 ~0xFFFF	
COM-16	Opt Parameter7	0	0~2	Set Modbus/TCP Comm. speed.
COM-94	Comm Update	NO		Communication related Keypad parameter is Updated.

(1) Option Type (Option card information, CNF-30)

The type of communication card installed in iS7 is displayed automatically.

If Modbus/TCP communication card is installed, "Ethernet" message is displayed automatically.

(2) Option Version (Option version information, COM-06)

Version of communication card installed in iS7 is displayed automatically.

(3) FBus Led (COM-09) – Option card LED information displayed

The ON/OFF state of LINK, SPD, ERR, CPU LED in Modbus/TCP communication card is displayed at Keypad parameter COM-09.

If you check COM-9 FBus LED with Keypad, 4 LEDs can be seen. According to order of LED of COM-09 (Left -> Right) LINK, SPD, ERR, CPU LED can be displayed.

When LED is ON, the relevant bit becomes 1 and when OFF, it becomes 0.

Bit	Description
0	CPU LED
1	ERROR LED
2	SPEED LED
3	LINK LED

COM-09 Led state example)

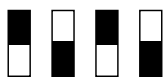

LINK LED	SPEED LED	ERR LED	CPU LED
ON	OFF	ON	OFF

(4) Modbus/TCP IP, Subnet Mask, Gateway Address (COM-10~15)

IP version that Ethernet option supports is v4. All the addresses and masks are expressed as Decimal number. Decimal number. Decimal number. Decimal number and a number between 0 and 255 is input for each decimal number.

In Ethernet option, all decimal number is supposed to change into hexadecimal number. That is, if they are expressed as Hexadecimal number. Hexadecimal number. Hexadecimal number. Hexadecimal number, a number between 00 and FF is input for each hexadecimal number. Also input dividing 2 higher hexadecimal numbers and 2 lower numbers.

Lower code numbers from Opt Parameter 10~15 represent 2 higher hexadecimal numbers and higher code numbers represent 2 lower hexadecimal numbers.

- Ex) For setting IP Address 196.168.10.131
 Change 196.168.10.131 into hexadecimal numbers. C4.A8.0A.83
 For COM-10 Opt Parameter1 input 0xC4A8
 For COM-11 Opt Parameter2 input 0x0A83.

(5) Modbus/TCP Baud rate (COM-16)

Modbus/TCP speed can be set within the range of 0~2.

Setting value	Speed
0	Automatic Speed Setting
1	100Mbps Full Duplex 10Mbps
2	Full Duplex

Automatic Speed Setting function is for setting automatically maximum speed in Network.

Full Duplex can transmit DATA through TX during receiving DATA through RX. On the contrary, Half Duplex can perform only one of RX or TX. That is, for maximum DATA transmitting and receiving, Full Duplex is twice faster than Half Duplex.

Refer) When communicating with PLC by 1:1 method, for changing communication speed of PLC after setting communication speed as Automatic Speed Setting (COM-16:0), pull out LAN Cable and plug it in again if automatic connection can not be done.

(6) Comm UpDate (COM-94)

For Option Parameters, when power inputs for the first time, the values set in Option are expressed. But if you set, the setting is not reflected at once.

If Comm Update is set as Yes, the value is reflected to Modbus/TCP communication card and only Modbus/TCP communication card operates again.

8. Inverter communication address

Refer to inverter IS-7 Manual Chapter 11. for communication function.

9. Modbus/TCP Frame

(1) Modbus/TCP Frame structure

MBAP Header(7 bytes)	PDU (5 bytes ~)
-----------------------	-----------------

Generally, Ethernet uses Ethernet II Frame.

MODBUS Application Protocol Header (MBAP Header)

MBAP Header structure is as below.

Region	Length	Description
Transaction Identifier	2 Bytes	As an identified transmitting number, is increased by 1 each time when Data frame is send to Server from Client.
Protocol Identifier	2 Bytes	Fixed as 0.
Length	2 Bytes	Modbus Data Frame length. From MBAP Header to Unit Identifier, Byte-unit length can be expressed.
Unit Identifier	1 Byte	When Modbus TCP and Modbus RTU are connected with Gate, Slave number is written. When Modbus TCP is only used, it is fixed as 0xFF.

(1) Protocol Data Unit (PDU)

AS an actual Data of Modbus TCP, consists of Function Code and Data.

Detail information will be given at “(2) Function Code Description.”

(2) Function Code Description

Modbus TCP can be divided into Client and Server. Client gives the command and Server responds to the command. Generally, as Client, there are PLC, HMI, PC so on, and Server means inverter.

① Read Holding Registers

It is a function for reading Data from Inverter (Server).

Frame Constitution that Client requires Server

Required Frame	Length	Value
Function Code	1 Byte	0x03
Comm. Address	2 Bytes	0x0000 ~ 0xFFFF
Required Data number	2 Bytes	1~16 (by LSIS Inverter standard)

Frame Constitution that Server responds to Master

Responded Frame	Length	Value
Function Code	1 Byte	0x03
Comm. Address	1 Byte	2 x Data required number
Required Data number	Data required number x 2 Bytes	The required data number from communication address

② Write Single Register

The function is used when modifying 1 Data of Inverter (Server).

Frame Constitution that Client requires Server

Required Frame	Length	Value
Function Code	1 Byte	0x06
Comm. Address	2 Bytes	0x0000 ~ 0xFFFF
Data Value	2 Bytes	0x0000 ~ 0xFFFF

Frame Constitution that Server responds to Master

Responded Frame	Length	Value
Function Code	1 Byte	0x06
Comm. Address	2 Bytes	0x0000 ~ 0xFFFF
Data Value	2 Bytes	0x0000 ~ 0xFFFF

③ Write Multiple Register

The function is used when modifying consecutive Data from 1 up to 16 of inverter (Server). Frame Constitution that Client requires Server

Required Frame	Length	Value
Function Code	1byte	0x10
Comm. Address	2bytes	0x0000 ~ 0xFFFF
Modifying Data number	2bytes	1~16 (by LSIS inverter standard)
Byte Count	1byte	2 X Data number
Data value to be modified	Data number x 2 bytes	Data for modifying

Frame Constitution that Server responds to Master

Responded Frame	Length	Value
Function Code	1 Byte	0x10
Comm. Address	2 Bytes	0x0000 ~ 0xFFFF
Modifying Data number	2 Bytes	1~16 (by LSIS inverter standard)

(3) Except Frame

Except Frame is for responding from Server if Error happens performing the required Frame when Client sends required Frame to Server.

Exception Frame Structure

Error Frame	Length	Value
Error Code	1byte	0x80 + Function Code that Client requires
Exception Code	1byte	0x0000 ~ 0xFFFF

Exception Code Type

Type	Code	Description
ILLEGAL FUNCTION	0x01	If non-supported Function is required.
ILLEGAL DATA ADDRESS	0x02	Data of not used address is required or to be modified.
ILLEGAL DATA VALUE	0x03	If you try to modify Data with the value that is against the permitted data range.
SLAVE DEVICE FAILURE	0x04	If there is error in Server (CAN Comm. ERROR with inverter, Option initialization ERROR, failure of DATA comm. with inverter)
SLAVE DEVICE BUSY	0x06	If Server can't respond due to other process (such as Inverter parameter initialization or option initialization setting)
WRITE PERMISSION ERROR	0x20	If you try to modify modifying prohibited parameter value with the Code that only exists at LS inverter.

10. LED Information

In iS7 Modbus/TCP communication card, 4 LEDs which indicate the Modbus/TCP state to the user are installed. In iS7 Modbus/TCP communication card, LEDs are displayed as below.

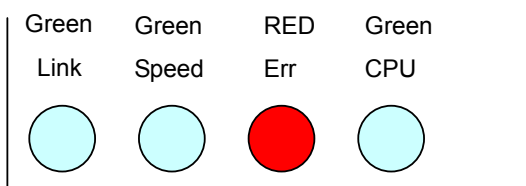

LED name	Color	Function
CPU	Green	BLINK – It means iS7 Modbus/TCP communication card CPU is operating normally when the power is well supplied to iS7 Modbus/TCP.
ERROR	Red	<p>OFF – It means iS7 Modbus/TCP communication card is normal without Error.</p> <p>ON – It means Modbus/TCP option EEPROM is faulty. Replace EEPROM.</p> <p>CPU, ERROR Flashing by turns. – Displayed if IP Address is set as 0.0.0.0.</p> <p>CPU, ERROR are Flashing - Displayed if CAN communication is interrupted.</p> <p>CPU with 0.5 sec, ERROR with 1sec period Flashing - Displayed if Opt Parameter is changed and Comm Update (Com94) is not done.</p>
Speed	Green	<p>ON – means Comm. Speed is 100Mbps.</p> <p>OFF – means Comm. Speed is 10Mbps.</p>
Link	Green	<p>ON – means it is ready to do communication.</p> <p>OFF – If communication cable wiring is incorrect, Link LED becomes OFF. Check communication Cable.</p>

Warranty

Product Name	LSIS Communication Option Card	Installation Date	
Model Name	SV-iS7 Modbus TCP Communication Card	Warranty Period	
Customer	Name		
	Address		
	Tel.		
Sales Office	Name		
	Address		
	Tel.		

Note

This product has been manufactured through the strict QC control and inspection of LS Industrial Systems. Warranty period is 12 months after installation or 18 months after manufactured when the installation date is unidentified. However, the guarantee term may vary on the sales term.

- In-warranty service information

- ▶ If the defective part has been identified under normal and proper use within the guarantee term, contact your local authorized LS distributor or LS Service center.

- Out-of-warranty service information

- ▶ The guarantee will not apply in the following cases.
 - ▶ Troubles are attributable to a user's intentional negligence or carelessness
 - ▶ Damage was caused by abnormal voltage and peripheral devices' malfunction (failure)
 - ▶ Damage was caused by natural disasters(earthquake, fire, flooding, lightning and etc)
 - ▶ When LS nameplate is not attached

Leader in Electrics & Automation

LS Industrial Systems

10310000962

■ **HEAD OFFICE**

Yonsei Jaedan Severance Bldg, 84-11 5 ga, Namdaemun-ro,
Jung-gu Seoul 100-753, Korea <http://eng.lsis.biz>
Tel. (82-2)2034-4643~4649 Fax.(82-2)2034-4879, 2034-4885

■ **LS Industrial Systems Tokyo Office >> Japan**

Address: 16F, Higashi-Kan, Akasaka Twin Towers 17- 22,
2-chome, Akasaka, Minato-ku, Tokyo 107-8470, Japan
Tel: 81-3-3582-9128 Fax: 81-3-3582-2667

e-mail: jschuna@lsis.biz

■ **LS Industrial Systems Dubai Rep. Office >> UAE**

Address: P.O.BOX-114216, API World Tower, 303B, Sheikh
Zayed road, Dubai, UAE. e-mail: hwyim@lsis.biz
Tel: 971-4-3328289 Fax: 971-4-3329444

■ **LS-VINA Industrial Systems Co., Ltd. >> Vietnam**

Address: LSIS VINA Congty che tao may dien Viet-Hung
Dong Anh Hanoi, Vietnam e-mail: srjo@hn.vnn.vn
Tel: 84-4-882-0222 Fax: 84-4-882-0220

■ **LS Industrial Systems Hanoi Office >> Vietnam**

Address: Room C21, 5th Floor, Horison Hotel, 40 Cat Linh,
Hanoi, Vietnam
Tel: 84-4-736-6270/1 Fax: 84-4-736-6269

■ **Dalian LS Industrial Systems co., Ltd. >> China**

Address: No. 15 Liaohexi 3 Road, economic and technical
development zone, Dalian, China e-mail: lixk@lgs.com.cn
Tel: 86-411-8273-7777 Fax: 86-411-8730-7560

■ **LS Industrial Systems (Shanghai) Co., Ltd. >> China**

Address: Room E-G, 12th Floor Huamin Empire Plaza,
No. 726, West Yan'an Road, Shanghai, China
Tel: 86-21-5237-9977

■ **LS Industrial Systems(Wuxi) Co., Ltd. >> China**

Address: 102-A National High & New Tech Industrial
Development Area, Wuxi, Jiangsu, China e-mail: Xugh@lgs.com.cn
Tel: 86-510-534-6666 Fax: 86-510-522-4078

■ **LS Industrial Systems Beijing Office >> China**

Address: B-tower 17th Floor, Beijing Global Trade Center building,
No. 36, BeiSanHuanDong-Lu, DongCheng-District, Beijing, China
Tel: 86-10-5825-6025

■ **LS Industrial Systems Guangzhou Office >> China**

Address: Room 1403, 14F, New Poly Tower, 2 Zhongshan Liu
Rad, Guangzhou, China e-mail: zhangch@lgs.com.cn
Tel: 86-20-8326-6754 Fax: 86-20-8326-6287

■ **LS Industrial Systems Chengdu Office >> China**

Address: Room 2907, Zhong Yin B/D, No. 35, Renminzhong(2)-
Road, Chengdu, China e-mail: hongkonk@vip.163.com
Tel: 86-28-8612-9151 Fax: 86-28-8612-9236

■ **LS Industrial Systems Qingdao Office >> China**

Address: 12th Floor, Guodong building, No52 Jindun Road,
Chengdu, China e-mail: bellkuk@hanmail.net
Tel: 86-532-580-2539 Fax: 86-532-583-3793

※ LS Industrial Systems constantly endeavors to improve its product so that
Information in this manual is subject to change without notice.

**Modbus TCP Option Board
SV-iS7 Series
2008.8**

© LS Industrial systems Co., Ltd 2008 All Rights Reserved.