

## RNet Option Board SV-iS7 Series



- \* Use this board after read Safety Instruction of this manual carefully before using and follow the instructions exactly.
- \* Please hand this user manual to end user and trouble shooting manager
- \* After read this manual, keep it at handy for future reference.

Before using the product, thank you for using our SV-iS7 RNet Option Board.

### Safety Instruction

- To prevent injury and danger in advance for safe and correct use of the product, be sure to follow the Safety Instructions.
- The instructions are divided as 'WARNING' and 'CAUTION' which mean as follow.



**WARNING**

**This symbol indicates the possibility of death or serious injury.**



**CAUTION**

**This symbol indicates the possibility of injury or damage to property.**

- The meaning of each symbol in this manual and on your equipment is as follows.



This is the safety alert symbol.



This is the dangerous voltage alert symbol.

- After reading the manual, keep it in the place that the user always can contact easily.
- Before you proceed, be sure to read and become familiar with the safety precautions at the beginning of this manual. If you have any questions, seek expert advice before you proceed. Do not proceed if you are unsure of the safety precautions or any procedure.

**WARNING**

- **Be cautious about dealing with CMOS elements of option board.**  
It can cause malfunction by static electricity.
- **Connection changing like communication wire change must be done with power off.**  
It can cause communication faulty or malfunction.
- **Be sure to connect exactly between Inverter and option board.**  
It can cause communication faulty or malfunction.
- **Check parameter unit when setting parameter.**  
It can cause communication faulty.

## 1. Introduction

RNet communication board makes the connection between PLC of LSIS and SV-iS7 inverter by a fast series communication so that PLC sequence program can control the inverter by high speed communication operation of 1 Mbps. Controlling and monitoring inverter by PLC sequence program makes it easier to install and modify the system.

A number of inverters can be connected by two communication lines so that saving installation time through simple wiring and easy replacement can be possible. Using extra devices of PLC and connecting with various systems including PC, the factory automation can be easier.

## 2. Technical date for RNet communication board

Item		Specifications
Transmission Speed		1Mbps
Encoding type		Manchester Bi-phase-L Frame synchronization type
Electric	Transmission distance (*1:per segment)	Maximum 750m
	Transmission distance (If repeater is used)	Maximum 750m x (6 repeaters +1) = 5.25km
	Transmission route	Twisted pair shielded cable RNet dedicated cable Cable name: LIREV-AMESB 1φ (PC 717 6705) Manufacturer: LS Cable
	Network terminal resistance	Terminal 120.8ohm 1/2W with an error range of 5% Built-in RNet communication board
Maximum points per station		Master + Slave = 64 points Master point : 0,Slave points :1~63
Maximum protocol size		256 bytes
Frame format		Field Bus standard IEC TC65 / SC65C / WG6 65C 90.8
Access method to service zone		Token Passing

Item	Specifications
Communication type	Connection Oriented Service Connectionless Service
Frame error check	CRC16

\*1) Segment

It means local network connecting all stations using the same Token without using any connecting devices (Gateway, EOC, and repeater).

### 3. RNet cable connection

Communication terminal name	Description
<b>TRX-</b>	Communication signal terminal N
<b>TRX+</b>	Communication signal terminal P
<b>SG</b>	Shield/Signal Ground
<b>TRX-</b>	Communication signal terminal N
<b>TRX+</b>	Communication signal terminal P

- ✓ Each two TRX-, TRX+ signals are connected in parallel.
- ✓ When installed at terminal, if you turn on the 1 switch of RNet communication board, terminal resistance of 120.8Ω, 1/2W is connected to communication signal terminal (TRX- and TRX+).
- ✓ Frame Ground is connected with inverter body. If inverter body is put to earth, SHIELD line is to be connected to Frame Ground.

### 4. Product Constituents

- RNet communication board: 1
- RNet manual: 1
- Fixed Screw (M3): 1

## 5. RNet communication board Interior and appearance /Installation

### (1) Interior

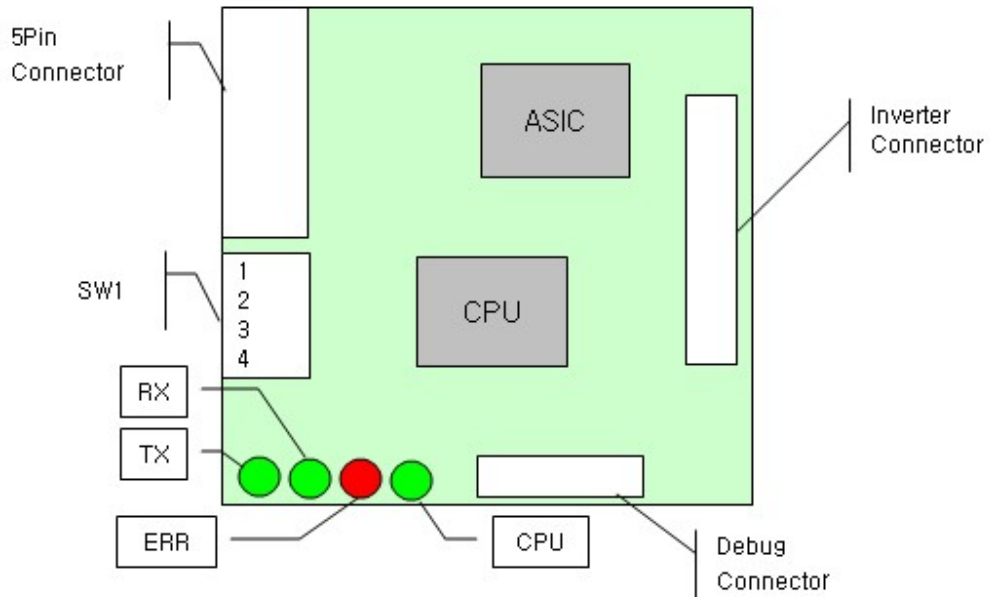

- ▶ SW1 : -. Pin 1 (terminal resistance connecting setting switch)  
On : 120.8 Ohm terminal resistance connected.
- . Pin 2 ~ 4 (Not used)

### (2) Appearance/Installation

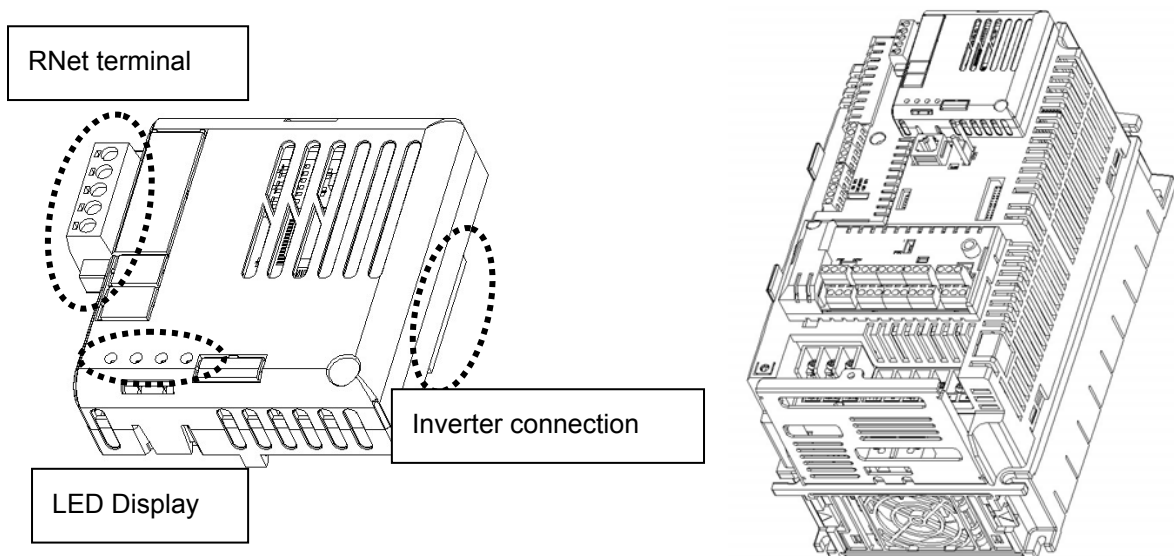

<RNet communication board appearance >

<RNet communication board installed  
in IS7 inverter>

## 6. RNet LED Information

Four LEDs are installed in iS7 RNet communication board informing the user of present RNet status. In iS7 RNet communication board, LED is located in the below turn.

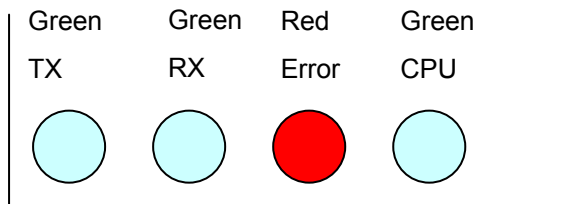

LED name	Color	Function
CPU	Green	<b>ON (0.5sec On, 0.5sec OFF)</b> – It shows that the power is fed to RNet communication board and CPU is operating normally.
TX	Green	TX Led is ON when inverter responds to the request of PLC.
RX	Green	RX Led is ON when inverter receives the request of PLC.
Error	Red	<p><b>Be On with the same period of CPU</b> – Displayed when Option Trip occurs. Option Trip is related with the CAN communication interruption between RNet card and inverter.</p> <p><b>Be On with the opposite period of CPU</b> – Network Configuration Error is displayed. Network Configuration Error is related with setting as 0 the address point of inverter or when the setting of Control Num of inverter is different from the Master.</p>

### 7. RNet related Keypad Parameter

Code	Parameter name	Initial value	Setting range	Description
CNF-30	Option Type-1	-	-	RNet: display the type of built-in communication board
DRV-06	Cmd Source	Fx/Rx-1	Keypad	Operation Source setting
			Fx/Rx-1	
			Fx/Rx-2	
			Int. 485	
			FieldBus	
			PLC	
DRV-07	Freq Ref Src	Keypad-1	Keypad-1	Frequency Source setting
			Keypad-2	
			V1	
			I1	
			V2	
			I2	
			Int. 485	
			Encoder	
			FieldBus	
			PLC	
COM-06	FBus S/W Ver	-	-	Display the version
COM-07	FBus ID	1	0~63	Communication Station address setting
COM-08	FBus BaudRate	1Mbps	1Mbps	Fixing the communication speed setting
COM-09	FBus Led	-	-	Communication board LED Display
COM-30	ParaStatus Num	3	0~8	Receiving data number
COM-31	Para Status-1	0x000A	0x0000 ~ 0xFFFF	Receiving Address 1
COM-32	Para Status-2	0x000E	0x0000 ~ 0xFFFF	Receiving Address 2



Code	Parameter name	Initial value	Setting range	Description
COM-33	Para Status-3	0x000F	0x0000 ~ 0xFFFF	Receiving Address 3
COM-34	Para Status-4	0x0000	0x0000 ~ 0xFFFF	Receiving Address 4
COM-35	Para Status-5	0x0000	0x0000 ~ 0xFFFF	Receiving Address 5
COM-36	Para Status-6	0x0000	0x0000 ~ 0xFFFF	Receiving Address 6
COM-37	Para Status-7	0x0000	0x0000 ~ 0xFFFF	Receiving Address 7
COM-38	Para Status-8	0x0000	0x0000 ~ 0xFFFF	Receiving Address 8
COM-50	Para Ctrl Num	2	0-8	Transmitting data number setting
COM-51	Para Control-1	0x0005	0x0000 ~ 0xFFFF	Transmitting Address 1
COM-52	Para Control-2	0x0006	0x0000 ~ 0xFFFF	Transmitting Address 2
COM-53	Para Control-3	0x0000	0x0000 ~ 0xFFFF	Transmitting Address 3
COM-54	Para Control-4	0x0000	0x0000 ~ 0xFFFF	Transmitting Address 4
COM-55	Para Control-5	0x0000	0x0000 ~ 0xFFFF	Transmitting Address 5
COM-56	Para Control-6	0x0000	0x0000 ~ 0xFFFF	Transmitting Address 6
COM-57	Para Control-7	0x0000	0x0000 ~ 0xFFFF	Transmitting Address 7
COM-58	Para Control-8	0x0000	0x0000 ~ 0xFFFF	Transmitting Address 8
PRT-12	Lost Cmd Mode	None	None	Operation method when losing communication command
			Free-Run	
			Dec	
PRT-13	Lost Cmd Time	1.0 sec	0.1~120.0 sec	Decision time of Lost communication command time

**(1) Option Type-1 (CNF-30)**

**– Display the type of communication board**

- ✓ Option Type-1 displays the type of communication card built-in inverter
- ✓ If RNet communication board is installed properly and there is no error in RNet communication board, “RNet” is displayed.

**(2) Cmd Source (DRV-06)**

**– Operation command Source setting**

- ✓ At Cmd Source parameter, set the inverter operation command source. If you command operation by communication, set “FieldBus”.

**(3) Freq Ref Src (DRV-07)**

**– Frequency command Source setting**

- ✓ At Freq Ref Src parameter, set inverter frequency command source. If you command frequency by communication, set “FieldBus”.

**(4) FBus S/W Ver (COM-06)**

**– Display the version of communication board built-in inverter.**

- ✓ Version of communication card installed at inverter is displayed.

**(5) FBus ID (COM-07)**

**– Setting inverter address.**

- ✓ For communicating with Master, set communication address allocated to inverter.
- ✓ Setting from 1 to 63 is possible.
- ✓ You must not set the inverter address as 0 only RNet Master can have the 0 address. If you set address as 0, the LED of RNet Communication card will display Network Configuration Error.

**(6) FBus BaudRate(COM-08) – Communication speed display**

- ✓ The speed of RNet communication installed in inverter is fixed as 1Mbps. So, setting is impossible and only can display the speed information.

**(7) FBus Led (COM-09) – Communication card LED information display**

- ✓ The state of ON/OFF of TX, RX, ERR, CPU LED of RNet communication card is displayed at COM-09 through Keypad parameter.
- ✓ If you check COM-09 FBus LED through Keypad, LED can be seen. According to the LED order of COM-09 (left -> right), the information of TX, RX, ERR, CPU LED is displayed in this order.

COM-09 Led state Example)

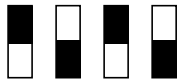

TX LED	RX LED	ERR LED	CPU LED
ON	OFF	ON	OFF

**(8) ParaStatus Num (COM-30) – Setting receiving data number**

- ✓ Communication Word data number that Master will receive from the inverter through communication is set.
- ✓ Inverter can send inverter 8 Words for the maximum.
- ✓ You must set exactly same with the number of receiving data of Master program.

**(9) Para Status-1~8 (COM-31~38) – Receiving address 1~8 setting**

- ✓ Inverter address through which inverter will receive data from Master is set.
- ✓ It is possible to set inverter address for communicating from COM-31 to COM-38, but inverter sends Master data as the number of COM-30 ParaStatus Num through communication.

**(10) Para Ctrl Num (COM-50) –Transmitting data number setting**

- ✓ Word data number is set that Master will transmit to inverter through communication.
- ✓ Inverter can receive 8 Word data from the Master for the maximum.
- ✓ You must set exactly same with the number of transmitting data of Master program.

**(11) Para Control-1~8 (COM-51~58) –Transmitting address 1~8 setting**

- ✓ Inverter address is set for data which Master gives to inverter.
- ✓ It is possible to set inverter address for communicating from COM-51 to COM-58, but Master transmits to inverter data as the number of COM-50 Para Ctrl Num through communication.

**(12) Lost Cmd Mode (PRT-12) – Operation method when losing communication command**

- ✓ Inverter operation method can be set for the case of communication command lost.
- ✓ Communication command lost is valid if DRV-06 Cmd Source is “FieldBus” or DRV-07 Freq Ref Src is set as “FieldBus”.
- ✓ If Lost Cmd Mode is set as “None” and communication command lost happens, Trip Message doesn’t occur if present operation state is kept.
- ✓ If Lost Cmd Mode is set as “Free-Run” or “Dec” and communication command lost happens, Free-Run operation will be done or Dec operation with “Lost Command” message display can be done.

**(13) Lost Cmd Time (PRT-13) – Communication command lost time**

- ✓ The standard time for communication command lost is set.
- ✓ Communication command lost is valid if DRV-06 Cmd Source is “FieldBus” or DRV-07 Freq Ref Src is set as “FieldBus” and then PRT-12 Lost Cmd Mode is “Free-Run” or “Dec”.

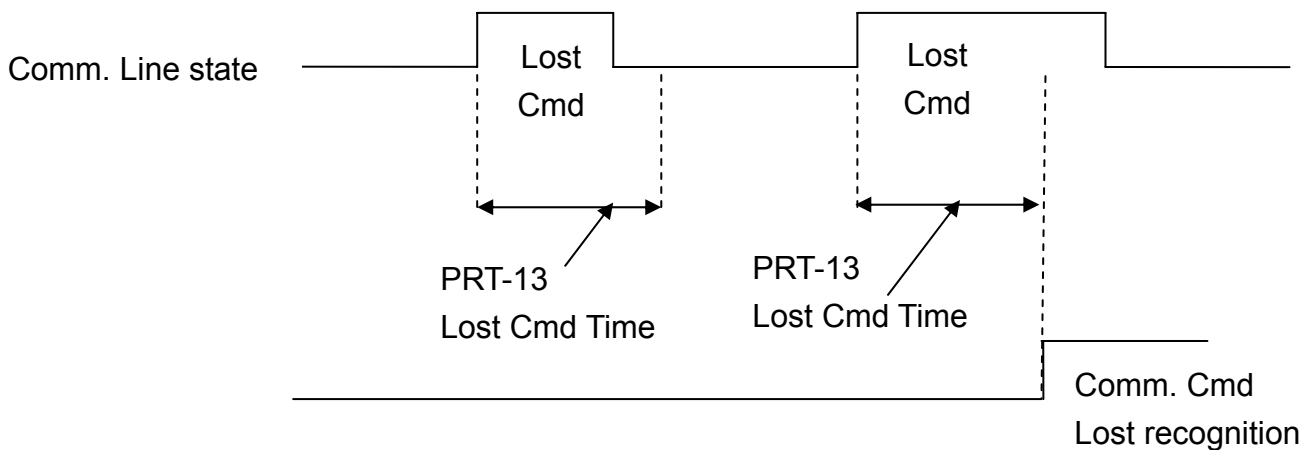

## 8. Connection to LSIS PLC with RNet

The below describes in brief how to connect LSIS PLC XGT with iS7 RNet Communication option card.

Visit LSIS website and download XG5000 Program and install it.

If you install, XG-PD Program and XG5000 Program are installed in PC.

★) **Transmitting and receiving is determined from the view of Master.**

### 8.1 H/W Installation

RNet Comm. Card is installed in iS7 inverter. When iS7 inverter turns ON, check if “RNet” message can be displayed at CNF-30 Option Type-1.

Install the PLC Hardware. As the picture below, attach power module and CPU to Base and connect RNet Master module (XGL-RMEA) to base.

Connect RNet Master module (terminal TRX+, TRX-) to iS7 RNet communication card (terminal TRX+, TRX-) using RNet dedicated cable for creating network.

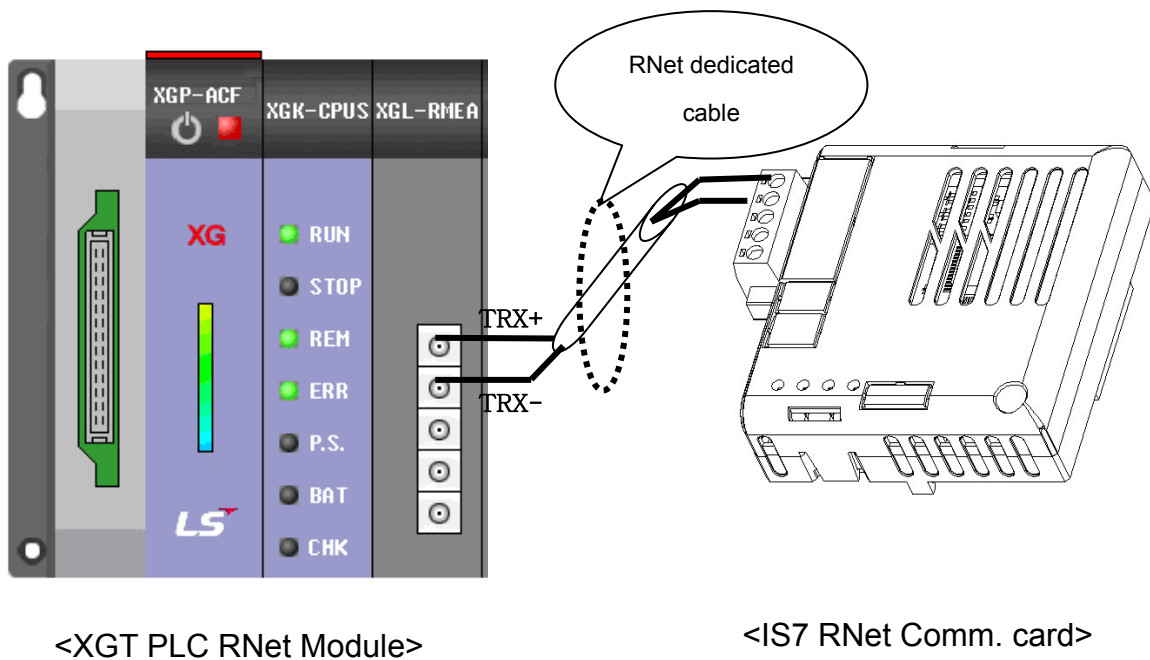

### 8.2 Inverter Parameter setting

Inverter parameter needed to set for RNet communication is as bellows.

- Inverter FieldBus ID
- Transmitting data number for communicating with Master
- Inverter address information for transmitting
- Receiving data number for communicating with Master
- Inverter's address information for receiving.

First, set inverter communication ID. Set COM-07 FBus ID. In the example, inverter FieldBus ID is set as 1. And set transmitting and receiving data for communicating with RNet. Here, 2 Word transmitting and 3 Word receiving communication is done. Set inverter Address for transmitting and Address for receiving.

➤ Parameter setting value at the example

Code	Parameter name	Value	Range	Description
COM-07	FBus ID	1	1~63	Field Bus ID Do not set 0 0 is fixed for Master.
COM-30	ParaStatus Num	3	0~8	Receiving data number
COM-31	Para Status-1	0x0007	0x0000 ~ 0xFFFF	Receiving Inverter Address information
COM-32	Para Status-2	0x0008	0x0000 ~ 0xFFFF	
COM-33	Para Status-3	0x000A	0x0000 ~ 0xFFFF	
COM-50	Para Ctrl Num	2	0~8	Transmitting data number
COM-51	Para Control-1	0x0005	0x0000 ~ 0xFFFF	Transmitting inverter Address information
COM-52	Para Control-2	0x0006	0x0000 ~ 0xFFFF	

### 8.3 Communicating with PLC

After finishing PLC RNet module setting (refer to PLC RNet module manual) if Inverter parameter setting is completed as above, communication between PLC and RNet is possible.

## Warranty

Product Name	LSIS Communication Option Card	Installation Date	
Model Name	SV-iS7 RNet Communication Card	Warranty Period	
Customer	Name		
	Address		
	Tel.		
Sales Office	Name		
	Address		
	Tel.		

### Note

This product has been manufactured through the strict QC control and inspection of LS Industrial Systems. Warranty period is 12 months after installation or 18 months after manufactured when the installation date is unidentified. However, the guarantee term may vary on the sales term.

- In-warranty service information
  - ▶ If the defective part has been identified under normal and proper use within the guarantee term, contact your local authorized LS distributor or LS Service center.
- Out-of-warranty service information
  - ▶ The guarantee will not apply in the following cases.
    - ▶ Troubles are attributable to a user's intentional negligence or carelessness
    - ▶ Damage was caused by abnormal voltage and peripheral devices' malfunction (failure)
    - ▶ Damage was caused by natural disasters(earthquake, fire, flooding, lightning and etc)
    - ▶ When LS nameplate is not attached

## Leader in Electrics & Automation

LS Industrial Systems

10310000963

■ **HEAD OFFICE**

Yonsei Jaedan Severance Bldg. 84-11 5 ga, Namdaemun-ro,  
Jung-gu Seoul 100-753, Korea <http://eng.lsis.biz>  
Tel. (82-2)2034-4643~4649 Fax.(82-2)2034-4879, 2034-4885

■ **LS Industrial Systems Tokyo Office >> Japan**

Address: 16F, Higashi-Kan, Akasaka Twin Towers 17- 22,  
2-chome, Akasaka, Minato-ku, Tokyo 107-8470, Japan  
Tel: 81-3-3582-9128 Fax: 81-3-3582-2667

e-mail: [jschuna@lsis.biz](mailto:jschuna@lsis.biz)

■ **LS Industrial Systems Dubai Rep. Office >> UAE**

Address: P.O.BOX-114216, API World Tower, 303B, Sheikh  
Zayed road, Dubai, UAE. e-mail: [hwyim@lsis.biz](mailto:hwyim@lsis.biz)  
Tel: 971-4-3328289 Fax: 971-4-3329444

■ **LS-VINA Industrial Systems Co., Ltd. >> Vietnam**

Address: LSIS VINA Congty che tao may dien Viet-Hung  
Dong Anh Hanoi, Vietnam e-mail: [srjo@hn.vnn.vn](mailto:srjo@hn.vnn.vn)  
Tel: 84-4-882-0222 Fax: 84-4-882-0220

■ **LS Industrial Systems Hanoi Office >> Vietnam**

Address: Room C21, 5th Floor, Horison Hotel, 40 Cat Linh,  
Hanoi, Vietnam  
Tel: 84-4-736-6270/1 Fax: 84-4-736-6269

■ **Dalian LS Industrial Systems co., Ltd. >> China**

Address: No. 15 Liaohexi 3 Road, economic and technical  
development zone, Dalian, China e-mail: [lixk@lgs.com.cn](mailto:lixk@lgs.com.cn)  
Tel: 86-411-8273-7777 Fax: 86-411-8730-7560

■ **LS Industrial Systems (Shanghai) Co., Ltd. >> China**

Address: Room E-G, 12th Floor Huamin Empire Plaza,  
No. 726, West Yan'an Road, Shanghai, China  
Tel: 86-21-5237-9977

■ **LS Industrial Systems(Wuxi) Co., Ltd. >> China**

Address: 102-A National High & New Tech Industrial  
Development Area, Wuxi, Jiangsu, China e-mail: [Xugh@lgs.com.cn](mailto:Xugh@lgs.com.cn)  
Tel: 86-510-534-6666 Fax: 86-510-522-4078

■ **LS Industrial Systems Beijing Office >> China**

Address: B-tower 17th Floor, Beijing Global Trade Center building,  
No. 36, BeiSanHuanDong-Lu, DongCheng-District, Beijing, China  
Tel: 86-10-5825-6025

■ **LS Industrial Systems Guangzhou Office >> China**

Address: Room 1403, 14F, New Poly Tower, 2 Zhongshan Liu  
Rad, Guangzhou, China e-mail: [zhangch@lgs.com.cn](mailto:zhangch@lgs.com.cn)  
Tel: 86-20-8326-6754 Fax: 86-20-8326-6287

■ **LS Industrial Systems Chengdu Office >> China**

Address: Room 2907, Zhong Yin B/D, No. 35, Renminzhong(2)-  
Road, Chengdu, China e-mail: [hongkonk@vip.163.com](mailto:hongkonk@vip.163.com)  
Tel: 86-28-8612-9151 Fax: 86-28-8612-9236

■ **LS Industrial Systems Qingdao Office >> China**

Address: 12th Floor, Guodong building, No52 Jindun Road,  
Chengdu, China e-mail: [bellkuk@hanmail.net](mailto:bellkuk@hanmail.net)  
Tel: 86-532-580-2539 Fax: 86-532-583-3793

※ LS Industrial Systems constantly endeavors to improve its product so that  
Information in this manual is subject to change without notice.

**RNet Option Board  
SV-iS7 Series  
2008.8**

© LS Industrial systems Co., Ltd 2008 All Rights Reserved.